

581 Series

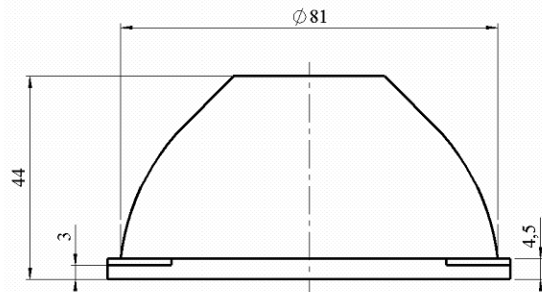
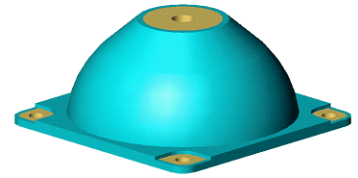

Construction

The 581 series dampers are made of elastomers with high mechanical fatigue properties and elevated damping, allowing to reach a transmissibility at resonance lower than 4 according with loads and input levels ($Q_{max} < 8$)
The metal parts are made of aluminium alloy with chromating processing
Approximate weight of damper : 170 grams

Applications

These isolators are perfectly suitable for insulation of sensitive equipments boarded or at fixed stations, like full bays, compressors, power of hydraulic units rotary machines, portable cabinets and measuring equipments, with a good isolation of frequencies from 15 Hz under high dynamic input
Their deflexion ability enabling them to damped shock or jerk applied on structure

Codification

The reference to be indicated for these dampers is at follows : 581-[AA]-[xx] ;
[AA] ; = GS for silicone rubber isolators
 = GN for neoprene rubber isolators
[xx] corresponding to the index of load range

Particular achievements with specific load range can be proposed, for any request, consult our engineering departments

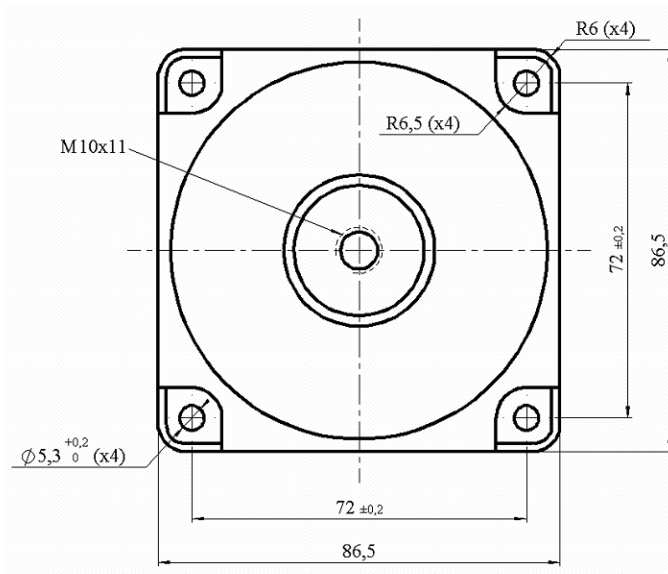

Characteristics

It is possible to apply the load in all directions but preferably in compression axis
The vibrations levels can reach $\pm 1,25mm$ and this for resonance frequencies from 10Hz
The axial to radial frequency factor is about 1,6
The maximum displacements are of $\pm 25mm$ in all directions
The operative temperature range is from $-55^{\circ}C$ to $+150^{\circ}C$ in execution GS, and from $-30^{\circ}C$ to $+80^{\circ}C$ in execution GN

The maximum loads are :

581-GN-01	581-GN-02	581-GN-03	581-GN-04
20,0 Kg	44,0 Kg	85,0 Kg	140,0 Kg
581-GS-01	581-GS-02	581-GS-03	
18,5 Kg	30,0 Kg	82,0 Kg	



581 Series

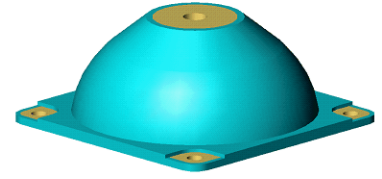

SILICONE Isolators (GS)

NEOPRENE Isolators (GN)

Load range under +/-0,4mm

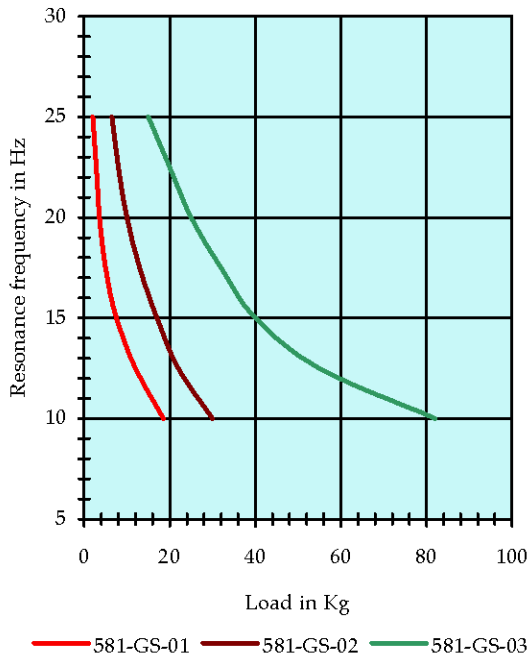

Load range under +/-0,4mm

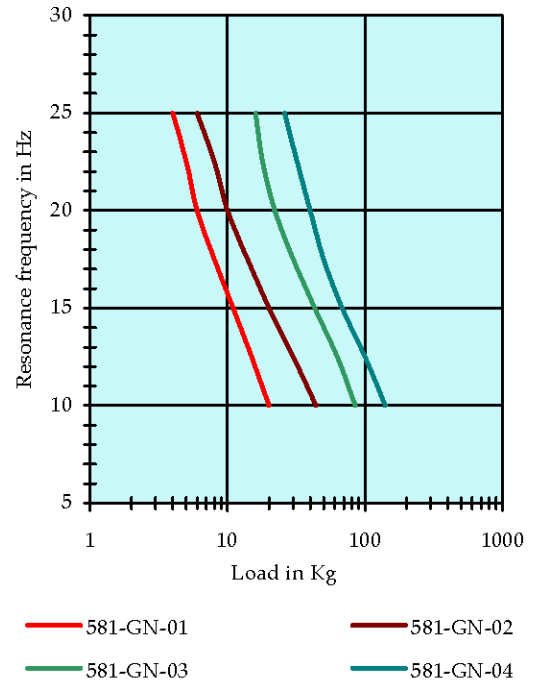

Typical dynamic rigidification behaviour

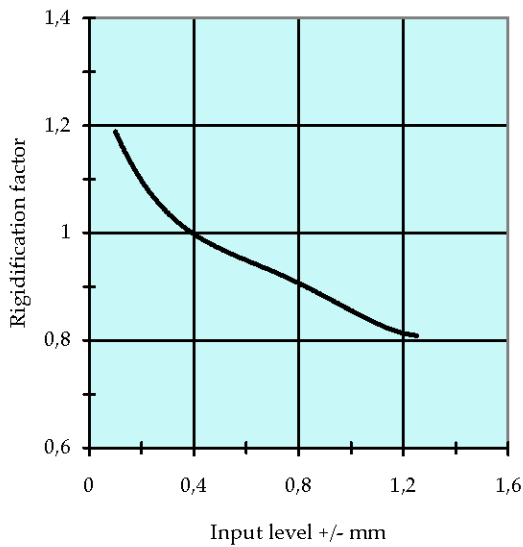

Typical dynamic rigidification behaviour

