

GB 530 Series

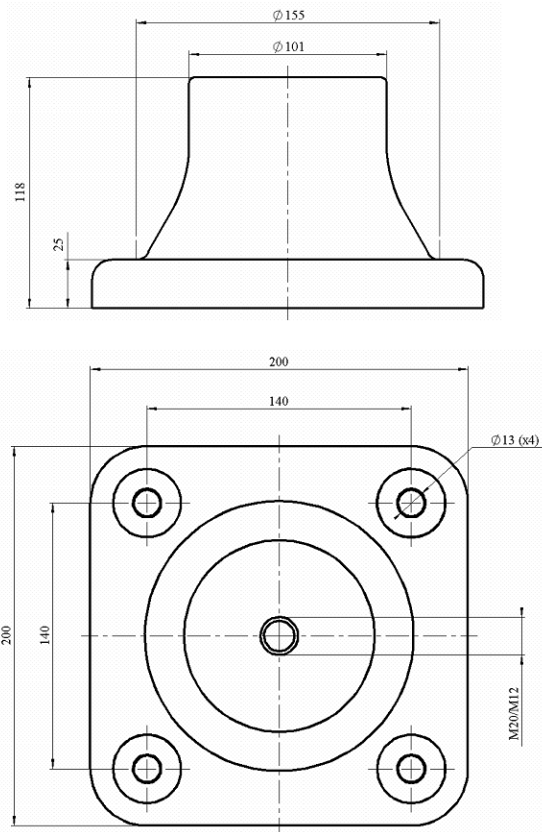
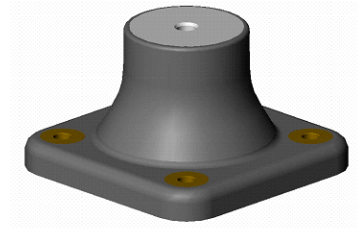

Construction

The GB530 series isolators are made in different combinations of executions feasible at demand
The standard is proposed with ferrous metal parts and natural rubber featuring very low creeping and long storage and service life
The particular execution could be with non magnetic parts or with high damping elastomers

Approximate weight of damper : 3,4 Kg

Applications

From their ability to accept very large displacements and their very low resonance frequency, they are perfectly suitable for damping of high vibrations and shock levels in Navy, Transportation and general Industrial applications, for equipments like pumps, generators, compressors, rotating machinery as well as suspended floors

NATO Codification :

GB530-NR1-M20-FM: 5340.14.511.6396

Codification

The reference to be indicated is : GB 530-[AA][x]-M[Y]-[BB], with

[AA] : type of rubber / NR : Standard (Very low creeping) / IR : Specific (Very high damping)

[x] : Loading index from 1 to 5

[Y] : Thread type, M20 for standard and M12 for specific

[BB] : FM for ferrous metal parts and NM for nonmagnetic metal parts

Example : GB 530-NR2-M20-FM : Standard execution – Max load 150 Kg – Threaded M20

Characteristics

High deflection under shock ability from ± 50 mm in all directions (70mm in compression)

Vibrations level could be reach $\pm 2,0$ mm for resonance frequency from 6Hz

The axial to radial frequency factor is of about 2

Stiffness not depending from vibration input level for NR execution

The operative temperature range is from -30°C to $+80^{\circ}\text{C}$ for NR range, and from -20°C to $+80^{\circ}\text{C}$ for IR range



GB 530 Series

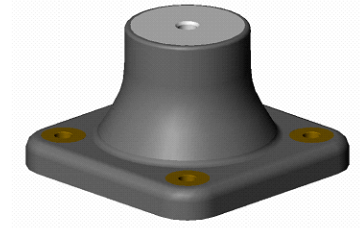

The maximum loads are :

GB 530 NR1	GB 530 NR2	GB 530 NR3	GB 530 NR4	GB 530 NR5
75 Kg	150 Kg	250 Kg	400 Kg	600 Kg
GB 530 IR1		GB 530 IR3		GB 530 IR5
80		300		600

Load range

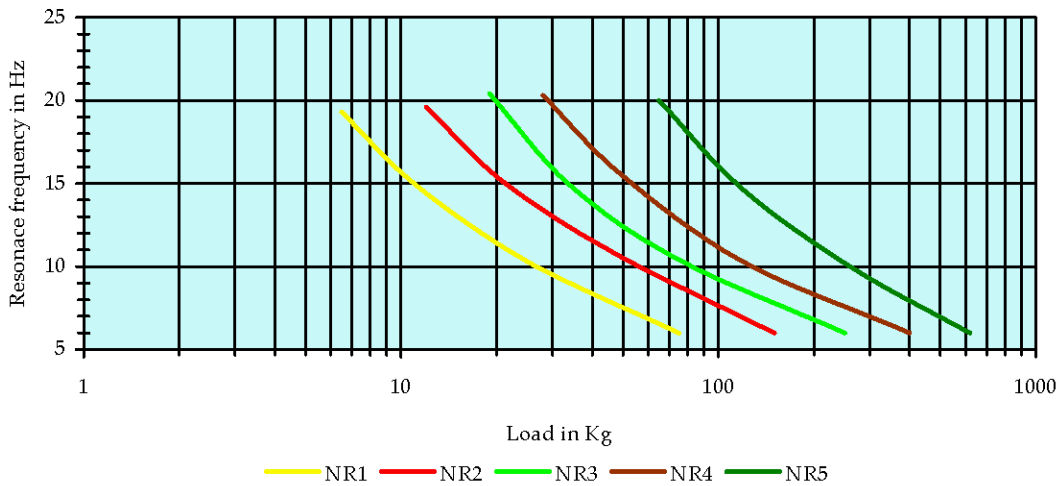

Load range under +/- 0,4mm

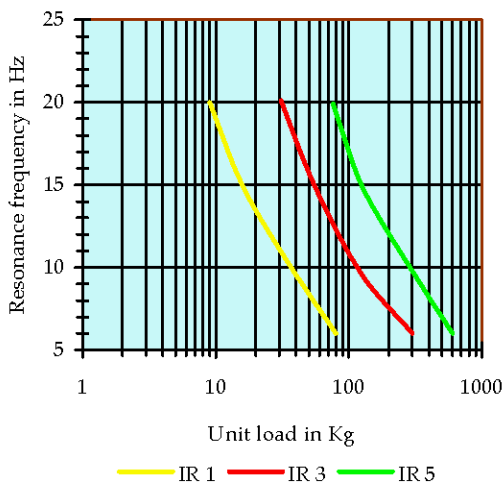

Typical dynamic rigidification behaviour

