

GKE-R Series

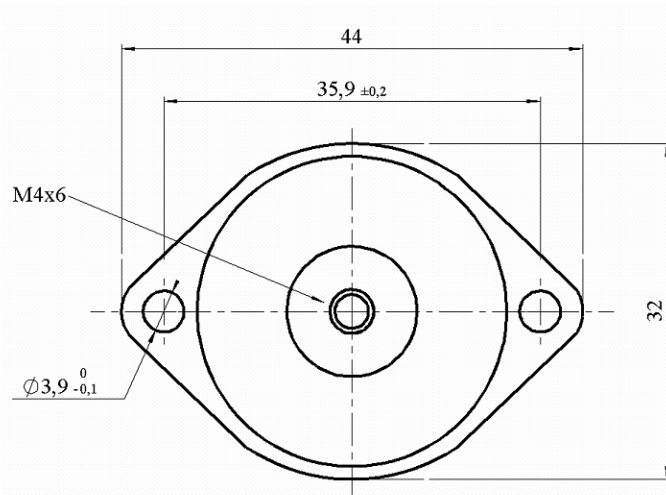
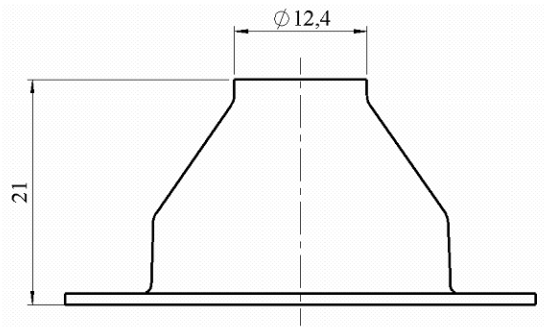
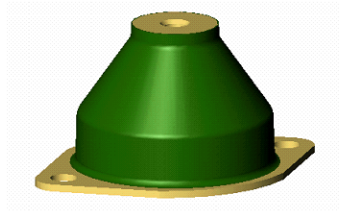

Construction

The GKE-R series dampers are made of elastomers with high mechanical fatigue properties and elevated damping, allowing to reach a transmissibility at resonance lower than 4 according with loads and input levels ($Q_{max} < 7$)

Approximate weight of damper : 15 grams

Applications

These isolators are suitable in a very large application field, for insulation of sensitive equipments like hard disks, video recorders, or other small electronic devices and computers on board or on fixed stations
In a small size, their deflexion ability enabling them to damped shock or jerk applied on structure

Codification

The reference to be indicated for these dampers is at follows : GKE-R[xx];
[xx] corresponding to the index of load range

Particular achievements with specific load range can be proposed, for any request, consult our engineering departments

Characteristics

It is possible to apply the load in all directions but preferably in compression axis
The vibrations levels can reach $\pm 1,5mm$ and this for resonance frequencies from 10Hz
The axial to radial frequency factor is about 1,4
The operative temperature range is from $-55^{\circ}C$ to $+150^{\circ}C$

The maximum loads are :

GKE-R1	GKE-R2	GKE-R3	GKE-R4	GHE-R5	GHE-R6
1,6 Kg	2,2 Kg	2,9 Kg	4,0 Kg	5,2 Kg	8,1 Kg

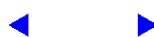

GKE-R Series

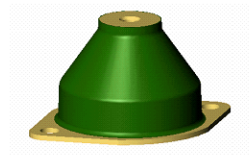

Load range under +/- 0,4mm

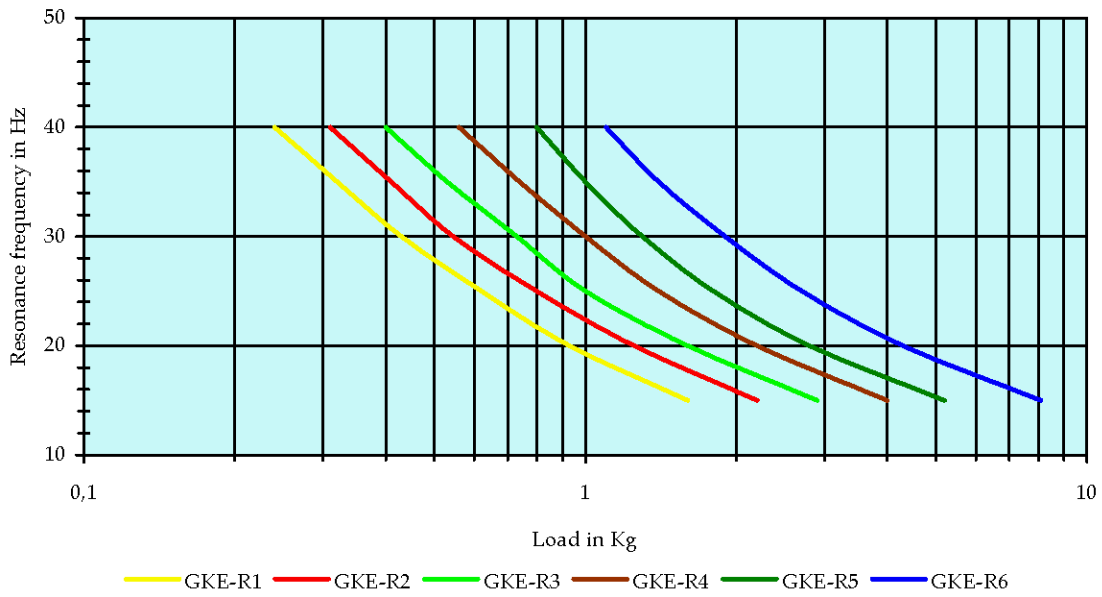

Typical dynamic rigidification behaviour

