

825 Series

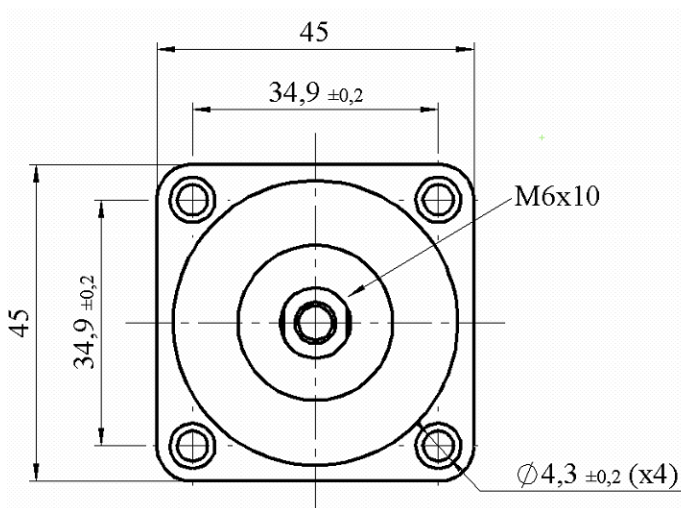
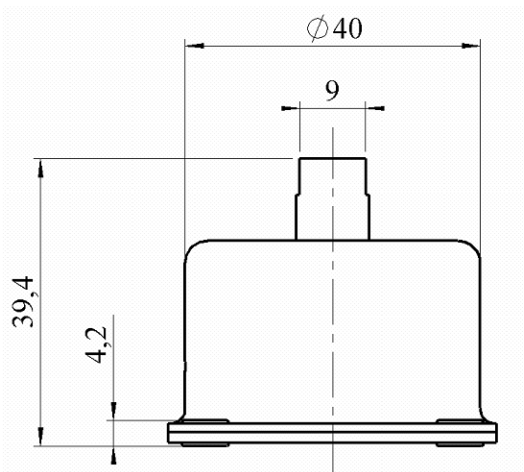
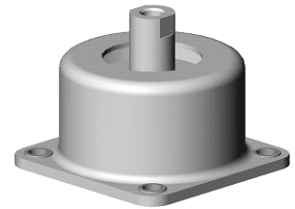

Construction

The 825 series dampers are made of stainless steel metal parts and elastomers with high mechanical properties and elevated damping, allowing to reach amplification at resonance lower than 3 according with loads and input levels ($Q_{max} < 5$)

Their construction is fail-safe

Approximate weight of damper : 85 grams

Applications

These dampers are perfectly suitable for insulation of electronic devices and computers, on board or mounted on fixed stations

Their low frequency behaviour allows to specify them for helicopter applications

Codification

The reference to be indicated for these dampers is at follows : 825-GS-[xx] ;

[xx] corresponding to the index of load range

Particular achievements with specific load range can be proposed, for any request, consult our engineering departments

Characteristics

The load must be applied in compression direction only

The vibrations levels can reach $\pm 1,5mm$ and this for resonance frequencies between 7 and 13Hz

For frequencies greater than 15 Hz, the maximum level should not exceed $\pm 0,4mm$

The axial to radial frequency factor is about 1,4

The operative temperature range is from $-55^{\circ}C$ to $+150^{\circ}C$

The maximum loads are :

825-GS-20	825-GS-35	825-GS-45	825-GS-55	825-GS-65	825-GS-75
1,0 Kg	2,0 Kg	2,7 Kg	3,4 Kg	4,3 Kg	6,0 Kg



825 Series

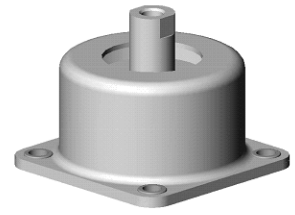

Load range under +/-1,5mm

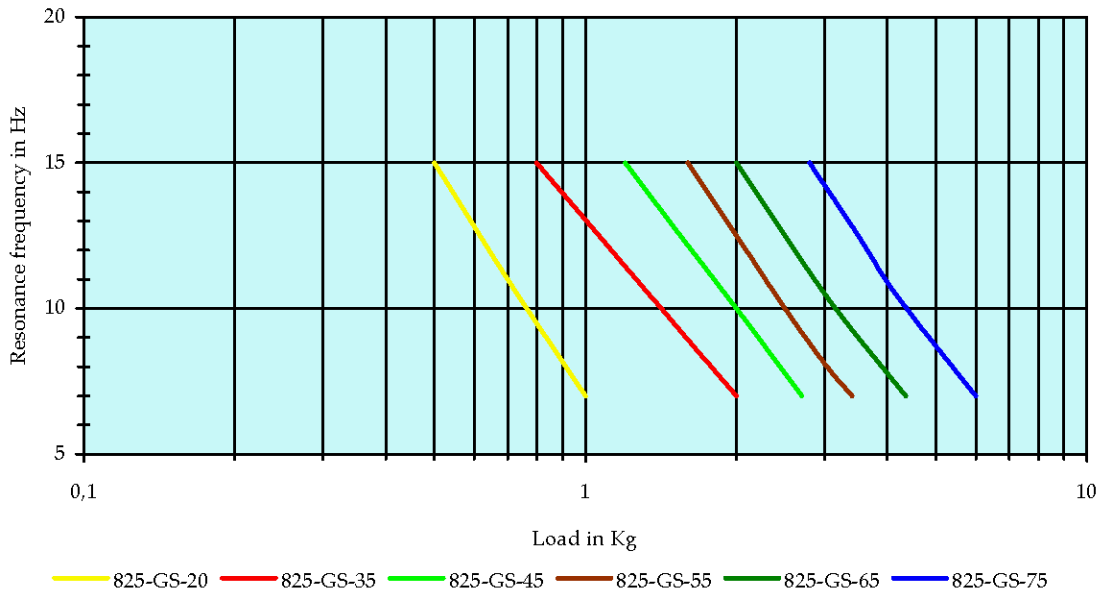

Typical rigidification behaviour

